

52/XC Cores (52-7400, 52-7402, 52-7403)

The 52/XC Cores (52-7400, 52-7402 and 52-7403) provide one serial port. The Serial port on the rear of the core is a RS232 port and can not be changed to RS422.

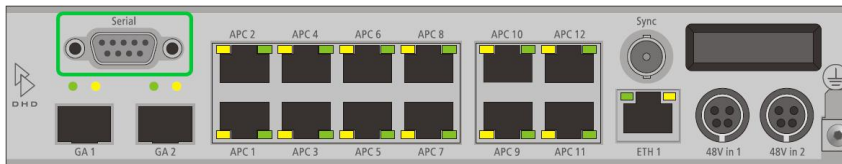

52-74xx XC Core - rear view with one male DSub-9 serial RS232 port

You can find the pin assignment for the female RS232 port on the core in the following drawing:

RS232 - DSub-9 female connector on core

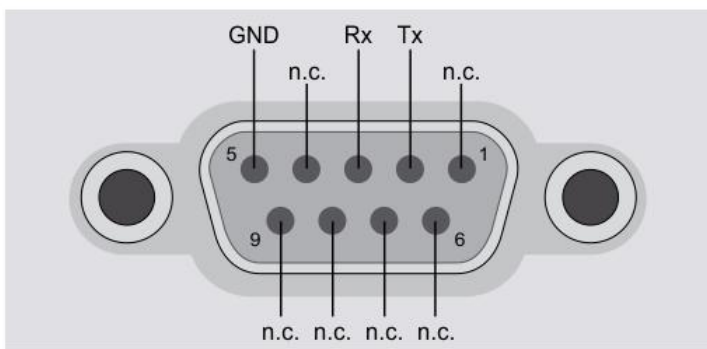

GND - all GND pins are internally connected to circuit ground but not to chassis/connector housing, use chassis/connector housing for cable shield only

n.c. - internally not connected

Pin assignment of the RS232 port on the core

With that pin assignment a standard extension cable (uncrossed) can be directly connected to a PC.

You can find the pin assignment for a **RS232 cable connector** in the following drawing:

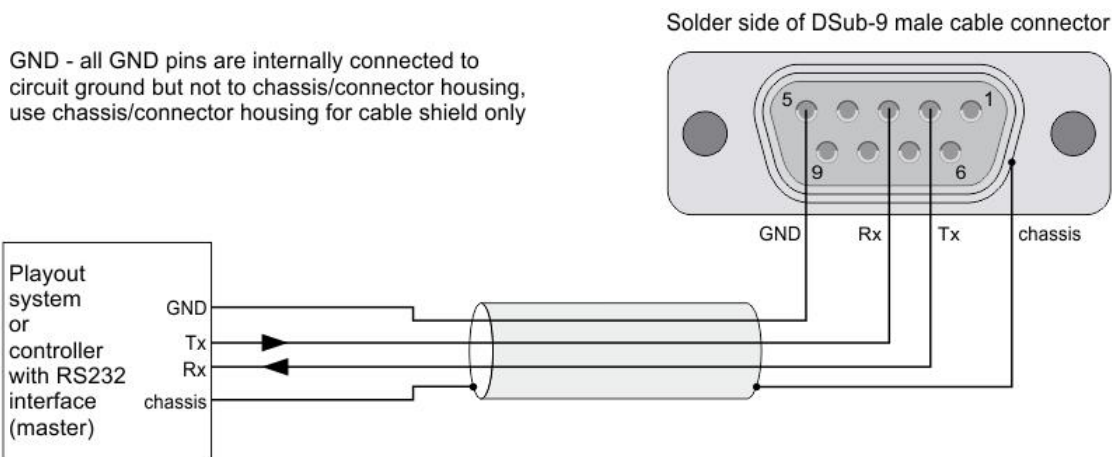

Pin assignment for the RS232 cable connector

52/XD Controller (52-7450)

The 52/XD Controller (52-7450) provides two serial ports - Serial 1 and Serial 2.

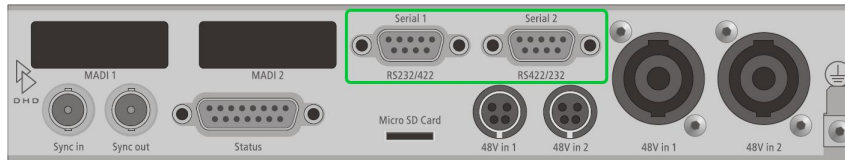

52-7450 XD Controller - rear view with serial connectors 1 and 2

Each port can be used for RS232 or RS422. The default configuration is:

- Serial 1: RS232
- Serial 2: RS422

To use RS232 with both ports, see the settings in the section [RS232 on Serial 1 and Serial 2](#).

To use RS422 with both ports, see the settings in the section [RS422 on Serial 1 and Serial 2](#).

If the serial port on the core is configured for **RS232**, you can find the pin assignment for this female port in the following drawing:

RS232 - DSub-9 female connector on core

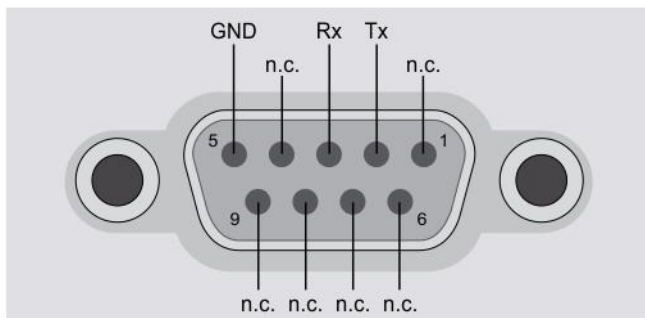

GND - all GND pins are internally connected to circuit ground but not to chassis/connector housing, use chassis/connector housing for cable shield only

n.c. - internally not connected

Pin assignment of the RS232 port on the core

With that pin assignment a standard extension cable (uncrossed) can be directly connected to a PC.

You can find the pin assignment for a **RS232 cable connector** in the following drawing:

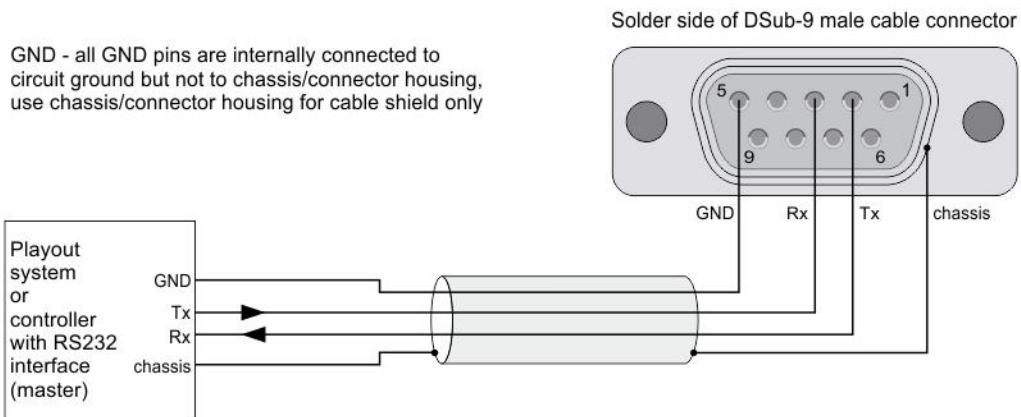

Pin assignment for the RS232 cable connector

If the serial port on the core is configured for **RS422**, you can find the pin assignment for this female port in the following drawing:

RS422 - DSub-9 female connector on core

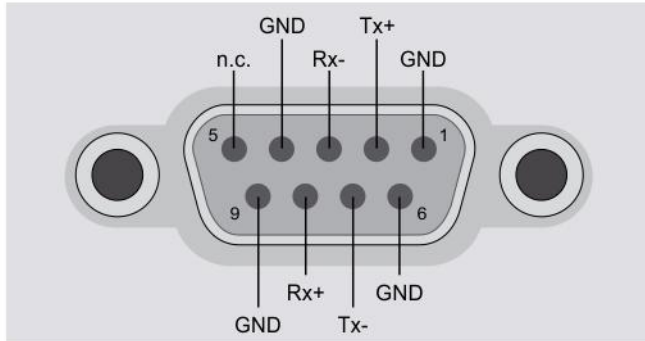

GND - all GND pins are internally connected to circuit ground but not to chassis/connector housing, use chassis/connector housing for cable shield only

n.c. - internally not connected

Pin assignment of the RS422 port on the core

You can find the pin assignment for a **RS422 cable connector** in the following drawing:

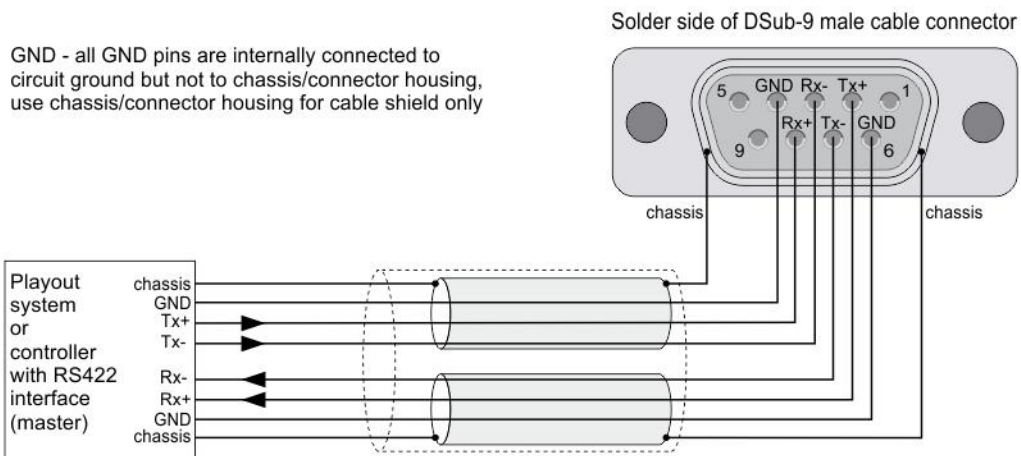

Pin assignment for the RS422 cable connector

Factory configuration RS232 / RS422

Each serial connector on XD Controllers can be used for RS232 or RS422. The default configuration is:

Serial 1: RS232
Serial 2: RS422

On the following picture you can see the factory default configuration inside the 52-7450.

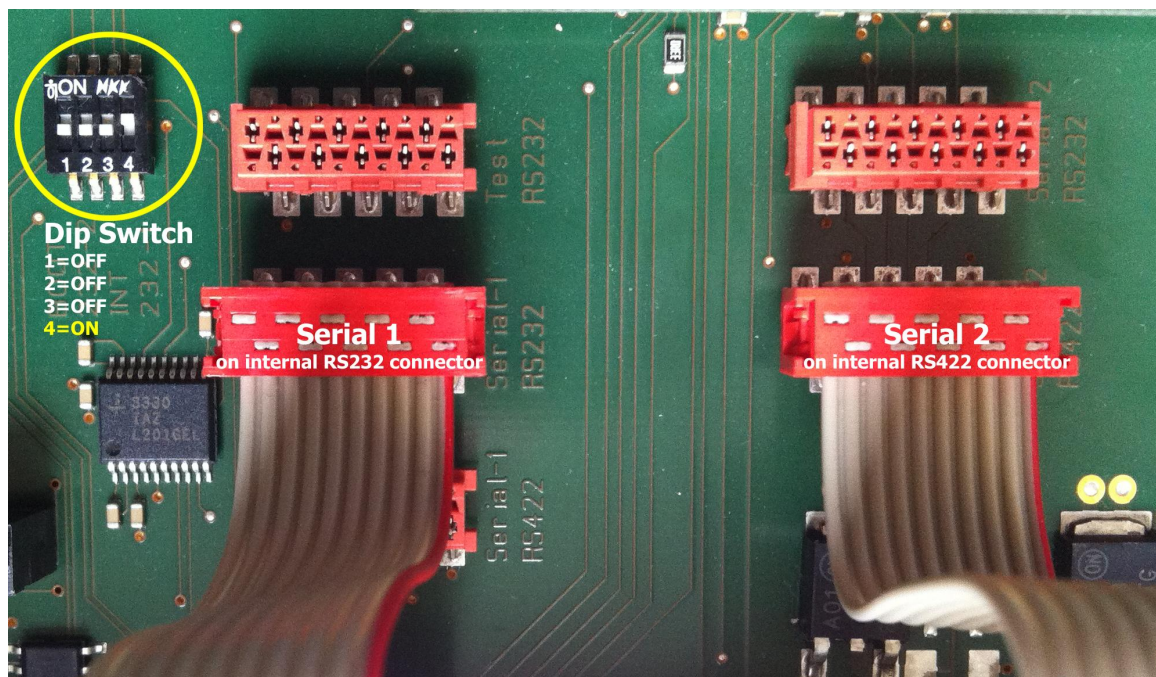

52-7450 internal cabling - factory default configuration

In the picture above you can see the default position of the ribbon cables coming from the D-sub connectors. In the top-left corner of the picture you can see a dip switch with its default setting:

1 = OFF
2 = OFF
3 = OFF
4 = ON

To change the used standard on the connector, you need to change the internal dip switch and the position of the internal ribbon cables.

To use RS232 with both connectors, see the settings in the section [RS232 on Serial 1 and Serial 2](#).

To use RS422 with both connectors, see the settings in the section [RS422 on Serial 1 and Serial 2](#).

RS232 on Serial 1 and Serial 2

To change the used standard on the connector, you need to change the internal dip switch and the position of the internal ribbon cables.

To use RS232 on Serial 1 and Serial 2, you need to change settings of the dip switch:

- 1 = OFF
- 2 = ON
- 3 = OFF
- 4 = ON

Connect the red plug on the ribbon cable of `Serial 1` to the internal connector `Serial-1 RS232` on the PCB.

Connect the red plug on the ribbon cable of `Serial 2` to the internal connector `Serial-2 RS232` on the PCB.

On the following picture you can see the corresponding configuration inside the 52-7450.

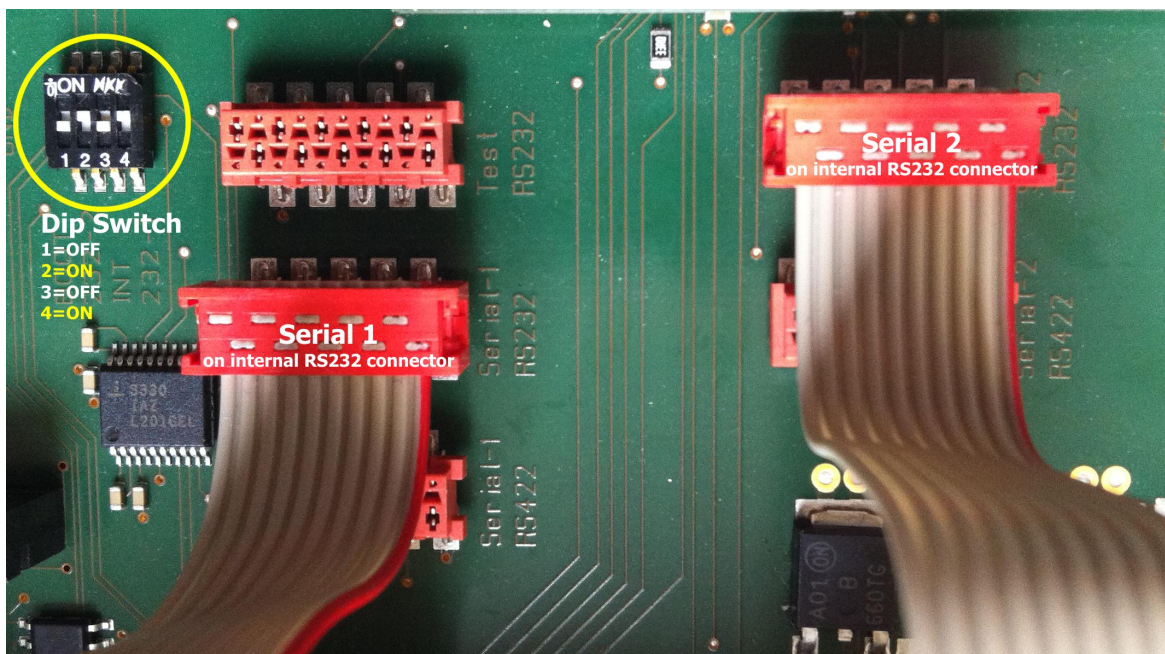

52-7450 internal cabling - RS232 on both serial connectors

RS422 on Serial 1 and Serial 2

To change the used standard on the connector, you need to change the internal dip switch and the position of the internal ribbon cables.

To use RS422 on Serial 1 and Serial 2, you need to change settings of the dip switch:

- 1 = OFF
- 2 = OFF
- 3 = OFF
- 4 = OFF

Connect the red plug on the ribbon cable of Serial 1 to the internal connector Serial-1 RS422 on the PCB.

Connect the red plug on the ribbon cable of Serial 2 to the internal connector Serial-2 RS422 on the PCB.

On the following picture you can see the corresponding configuration inside the 52-7450.

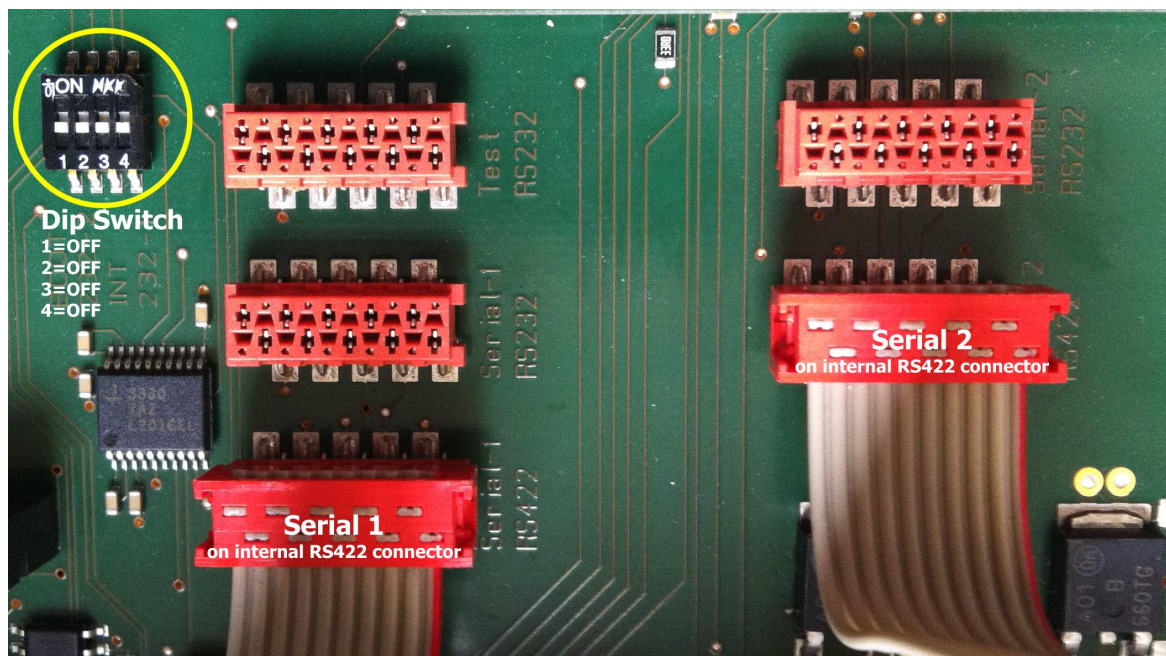

52-7450 internal cabling - RS422 on both serial connectors

52/XS Cores (52-1801, 52-1804)

The 52/XS Cores (52-1801 and 52-1804) provide one serial port. The Serial port on the rear of the core is a RS232 port and can not be changed to RS422.

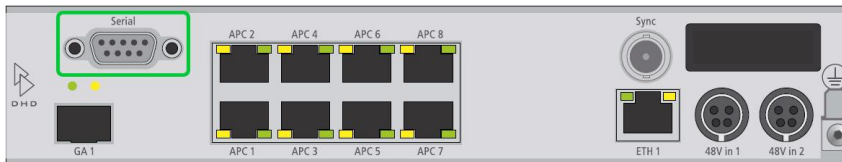

52-1801 XS Core - rear view with one serial RS232 port

You can find the pin assignment for the female RS232 port on the core in the following drawing:

RS232 - DSub-9 female connector on core

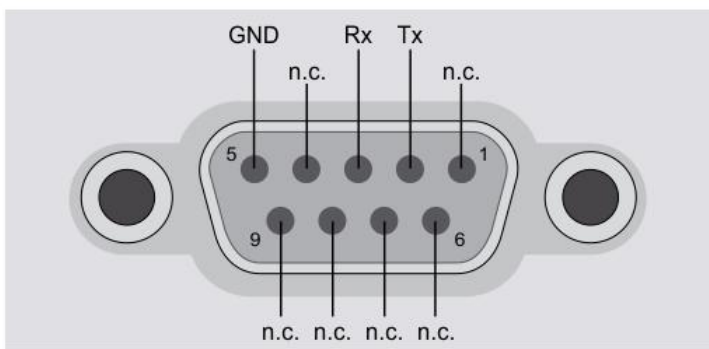

GND - all GND pins are internally connected to circuit ground but not to chassis/connector housing, use chassis/connector housing for cable shield only

n.c. - internally not connected

Pin assignment of the RS232 port on the core

With that pin assignment a standard extension cable (uncrossed) can be directly connected to a PC.

You can find the pin assignment for a **RS232 cable connector** in the following drawing:

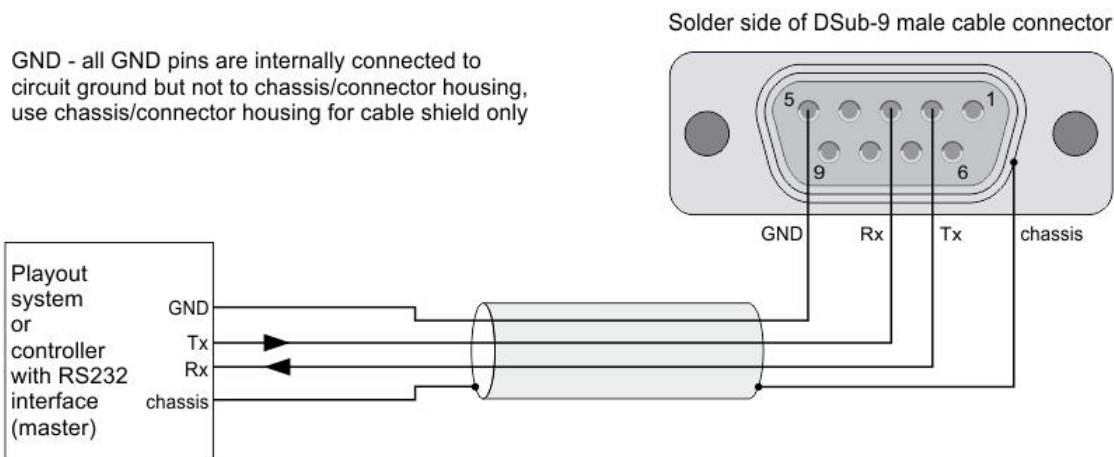

Pin assignment for the RS232 cable connector